

Busbar Trunking Systems

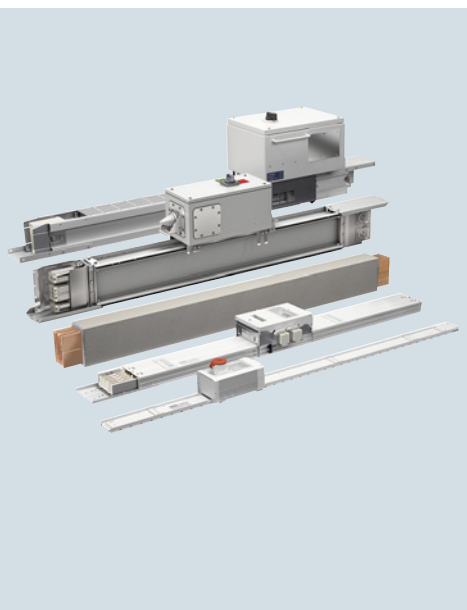

17/2

17/4

17/6

Introduction

Introduction

Features overview

Principles of busbar trunking planning

For further information,
see [Catalog LV 70](#)



For further technical product information:

[Installation manual](#)

SIVACON 8PS
- Installation with BD2 system
Article No.: A5E02126899-02

[Planning Manual](#)

SIVACON 8PS
- Planning with SIVACON 8PS
Article No.: A5E01541017-04

Siemens Industry Online Support:

www.siemens.com/lowvoltage/product-support

→ Entry type:
Application example
Certificate
Characteristic
Download
FAQ
Manual
Product note
Software archive
Technical data

Siemens LV 10 · 10/2017

Busbar Trunking Systems

Introduction

Overview

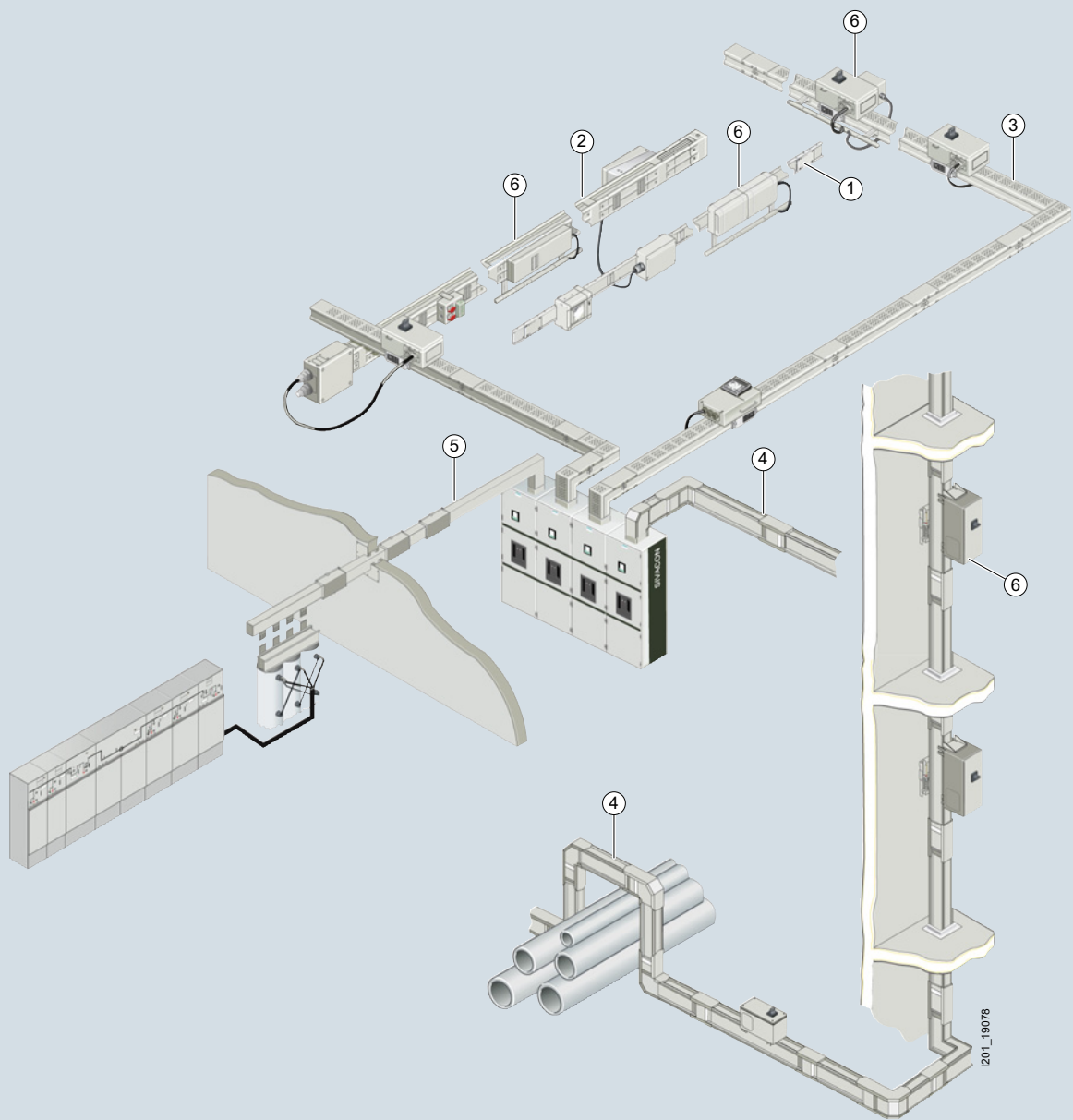

- ① BD01 system
- ② BD2 system
- ③ LD system

- ④ LI system
- ⑤ LR system
- ⑥ Communication-capable busbar trunking systems for connection to the following bus systems:
 - KNX (EIB / Instabus)
 - AS-Interface
 - PROFIBUS
 - PROFINET
 - Modbus

1201_19078

Benefits

① **BD01 system up to 160 A**

The busbar trunking system for power distribution in the skilled trades and business:

- High degree of protection up to IP55
- Flexible power supply
- Easy and quick planning
- Time-saving mounting
- Reliable mechanical and electrical connection technology
- High stability, low weight
- Few basic modules required
- Storage-friendly system
- Variable changes of direction
- Versatile tap-off units
- Positive opening and closing of tap-off points

② **BD2 system up to 1250 A**

The busbar trunking system for operation in the harsh industrial world:

- High degree of protection up to IP55
- Easy and quick planning
- Time-saving and economical mounting
- Reliable and safe operation
- Flexible modular system with simple solutions for every application
- Early planning of the power distribution system without exact knowledge of load locations
- Early readiness for operation thanks to fast and simple mounting
- Innovative design: No more compensation boxes to compensate elongation
- Codable tap-off units and tap-off points
- Sealable throughout

③ **LD system up to 5000 A**

The busbar trunking system for optimized power distribution in industry:

- Degree of protection up to IP54
- Quick and easy mounting
- Reliable and safe operation
- Space-saving, compact design up to 5000 A in one enclosure
- Load outgoing feeders up to 1250 A
- Type-tested connection to distribution boards and transformers

④ **LI system up to 6300 A**

The busbar trunking system for power transmission and distribution in infrastructure – e.g. in multistory buildings – and in industrial applications:

- Reliable and easy mounting
- Reliable and safe operation
- Load outgoing feeders up to 1250 A
- Tested connection to distribution boards (type-tested connection to SIVACON S8) and transformers

⑤ **LR system up to 6300 A**

The busbar trunking system for power transmission under extreme ambient conditions (IP68).

[Detailed information about this system is available from the Siemens branch located close to you.](#)

⑥ **Communication-capable busbar trunking systems**

Communication-capable function expansions for combination with known tap-off units:

- Can be used with the BD01, BD2, LD and LI systems
- Uses:
 - Building control
 - Switching, reporting and remote operation
 - Consumption recording and remote monitoring of decentral power tap-off units
 - Interlinking of various trades
- Connection to the KNX (EIB/Instabus), AS-Interface and PROFIBUS, PROFINET and Modbus bus systems
- Integrated, efficient and future-proof solution thanks to the integration of measuring devices in energy management solutions according to ISO 50001
- Flexible with plug-in tap-off units including measuring devices
- Cost-efficient with greater transparency of the energy consumption
- Reliable thanks to central control of the power distribution

More information

Catalog LV 70 - Busbar Trunking Systems BD01, BD2 up to 1250 A

German: Article No. E86060-K1870-A101-A8
English: Article No. E86060-K1870-A101-A8-7600

SIVACON 8PS busbar trunking systems configurator

Busbar trunking systems up to 1250 A can be ordered using the product configurator (selection aid).

The following configurators are available:

- SIVACON 8PS BD01 system, 40 ... 160 A
- SIVACON 8PS BD2 system, 160 ... 1250 A

This selection aid can be accessed through the Industry Mall and is also included in Interactive Catalog CA 01 on a DVD, which is available free of charge.

Manual

Planning with SIVACON 8PS - busbar trunking systems up to 6300 A

German: Article No. A5E01541017-04
English: Article No. A5E01541101-04

Leaflet

English: Energy: flexible, safe, everywhere!
SIVACON 8PS busbar trunking systems
German: Article No. IEMMS-B10032-00
English: Article No. EMMS-B10032-00-7600





Internet

www.siemens.com/busbar

Busbar Trunking Systems

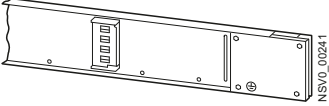
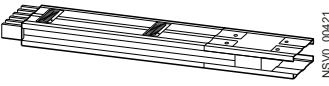
Features overview

Overview

| Busbar trunking systems | Rated current A | Rated operational voltage V AC | Frequency Hz | Number of active conductors | Degree of protection | Ambient temperature, min./max. °C |
|---|--------------------------------|-----------------------------------|-----------------|--------------------------------|----------------------|-----------------------------------|
| BD01  | 40 63 100 125 160 | 400 | 50 | 4 (PE = enclosure) | Up to IP55 | -5/+40 |
| BD2A BD2C  | 160 ... 1000 160 ... 1250 | 690 | 50 | 5 | Up to IP55 | -5/+40 |
| LDA1 ... LDA8 LDC2 ... LDC8  | 1100 ... 4000 2000 ... 5000 | 1000 | 50 | 4 or 5 | Up to IP54 | -5/+40 |
| LI-A0800 ... LI-A5000 LI-C1000 ... LI-C6300  | 800 ... 5000 1000 ... 6300 | 1000 | 50 | 3, 4, 5, 6 (PE = enclosure) | Up to IP66 | -5/+50 |
| LRA01 ... LRA29 LRC01 ... LRC29  | 400 ... 5000 630 ... 6300 | 1000 | 50 | 4, 5 | IP68 | -5/+40 |

| Mounting position | Length m | Tap-off points | Tap-off units | Material | Fire load kWh/m | Can be combined with communication-capable tap-off units for |
|---|--------------|--|---------------|---|--|---|
| Edgewise, flat (outgoing points downwards) | 2 3 | On one side every 0.5 or 1 m | Up to 63 A | Insulated Al or Cu conductors, painted sheet-steel enclosure | 0.76 | Lighting control |
| Edgewise, flat and vertical | 0.5 ... 3.25 | Without On two sides offset every 0.25 or 0.5 m | Up to 530 A | Al or Cu busbars, painted sheet-steel enclosure | 0.6 ... 0.67 (without tap-off points) | Lighting control, remote switching, signaling and consumption recording |
| Horizontal, edgewise and vertical | 0.5 ... 3.2 | Without On one side every 1 m On two sides every 1 m | Up to 1250 A | Insulated Al or Cu busbars, painted sheet-steel enclosure | 4.16 ... 8.83 (without tap-off points) | Remote switching, signaling and consumption recording |
| Horizontal, edgewise and vertical | 0.35 ... 3 | Without Up to 3 tap-off points on 3 m | Up to 1250 A | Insulated Al or Cu busbars, painted aluminum enclosure | 2.13 ... 15.34 | Remote switching, signaling and consumption recording |
| Horizontal, edgewise and vertical | 0.5 ... 3 | Without Selectable on one side | Up to 630 A | Epoxy resin system, Al or Cu busbars | -- | -- |

Busbar Trunking Systems

Principles of busbar trunking planning

Overview

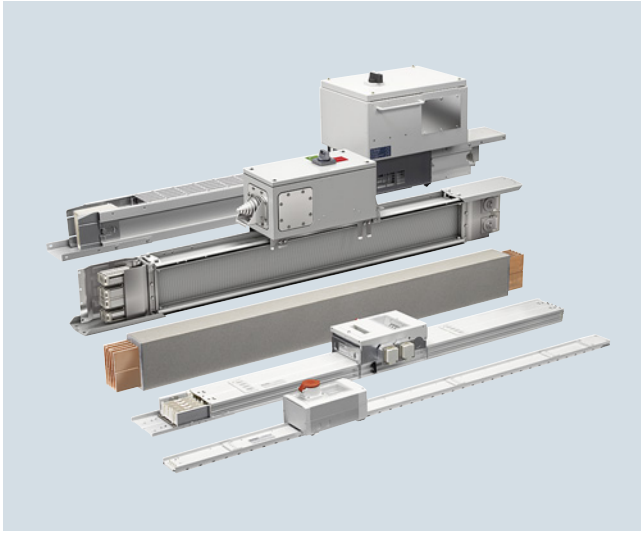

Trunking units for currents from 40 to 6300 A

When it comes to developing a power distribution concept complete with the configuration of systems and system components, the end user's requirements have to be coordinated with the manufacturer's possibilities.

Descriptions are provided accordingly of the individual systems, their technical features and their fields of application. Another element is the graphic representation of the various busbar trunking elements. All details of importance for the planning work are emphasized and explained.

You will find ideas for a ready-to-use planning solution under "Configuration information" in Chapters 3 and 4 of Catalog LV 70. For example, the basics of dimensioning are presented in detail along with in-depth information on topics such as system construction, short-circuit protection, fire protection and functional maintenance.

Services and engineering tools are available from Siemens to simplify the drawing up of customer specifications.

General information

When developing the planning concept of a power supply system, it is necessary not only to consider the standards and specifications in force but also to clarify the correlations between economy and technology. Electrical equipment such as distribution boards and transformers must be dimensioned and selected so that they represent an optimum in their entirety and not just individually.

All components must be sufficiently dimensioned for the loads which arise in the event of a fault as well as during operation at rated values. Other decisive points to be considered when drawing up the power concept are:

- The type, utilization and shape of building (e.g. high-rise, flat-roof and number of storeys)
- Determination of load centers and selection of possible supply routes and locations for transformers and main distribution boards
- Determination of building-related connected loads according to specific loads per unit area dependent on the building's use
- Specifications and requirements imposed by the building authorities
- Requirements imposed by the power supply companies

The result will never be a single solution but several versions which must be assessed with regard to their technical and economic implications. The following requirements are paramount in this connection:

- Easy and clear-cut planning
- Long endurance
- High availability
- Low fire load
- Flexible adaptation to changes within the building

In most applications these requirements are easily met by the use of suitable busbar trunking systems. For this reason, busbar trunking systems rather than the cable installation method are being used more and more often by engineering offices for the transmission and distribution of power. Siemens offers busbar trunking systems from 40 to 6300 A:

- The BD01 busbar trunking system from 40 A to 160 A for supplying power to workshops with tap-off units up to 63 A
- The BD2 system from 160 A to 1250 A for supplying power to medium-size loads in buildings and in industry
- The ventilated LD system from 1100 A to 5000 A for supplying loads with medium power consumption in industry
- The LI sandwich system from 800 A to 6300 A for power distribution with IP55 and power transmission of high volumes of power up to IP66 in infrastructure – e.g. in multistorey buildings – and in industrial applications
- The LR encapsulated system from 400 A to 6300 A for power transmission in extreme ambient conditions (IP68)